



Rewarding Learning

ADVANCED SUBSIDIARY (AS)
General Certificate of Education
2024

Centre Number

--	--	--	--	--

Candidate Number

--	--	--	--

Technology and Design

Assessment Unit AS 1

assessing

Systems and Control or
Product Design

MV24

[STE12]

MONDAY 13 MAY, AFTERNOON

Time

1 hour, plus your additional time allowance.

Instructions to Candidates

Write your Centre Number and Candidate Number in the spaces provided at the top of this page.

You must answer the questions in the spaces provided.

Do not write on blank pages.

Questions which require drawing or sketching should be completed using an H.B. pencil.

All other questions must be completed using black ink only.

Do not write in pencil.

Answer **both** questions in **either** Section A, B or C.

For all questions requiring calculations, show your working out.

Information for Candidates

The total mark for this paper is 40.

Figures in brackets printed at the end of each question indicate the marks awarded to each question or part question.

Blank Page

(Questions start overleaf)

Section A

Electronic and Microelectronic Control Systems

Answer **both** questions in this section.

- 1 (a) The circuit shown in **Fig. 1** has been developed to operate a relay when the single pole single throw (SPST) micro switch Sw has been momentarily closed.

Fig. 1

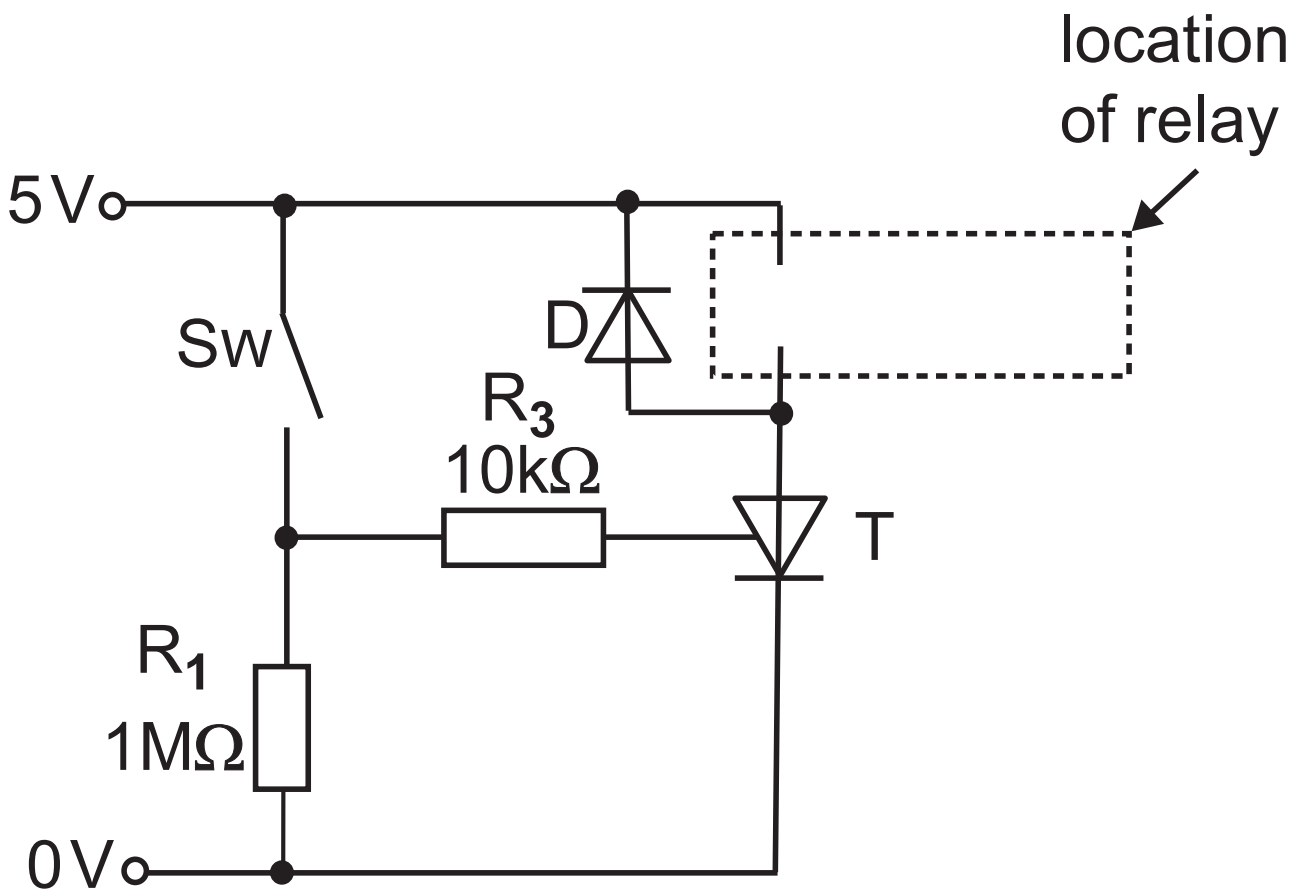

(i) Describe the distinguishing feature of a micro switch. [2 marks]

(ii) Explain the operation of the thyristor **T** in **Fig. 1** when the micro switch **Sw** is briefly closed and opened again. Your answer should make reference to the gate, anode and cathode terminals of the thyristor. [3 marks]

(iii)As a further development to the circuit shown in **Fig. 1** a means of resetting the circuit is to be added by using either a push to make switch or a push to break switch. On **Fig. 1** add the following: [2 marks]

- a push to make switch connected to act as a reset for the circuit.
- an **X** to mark where a push to break switch could be connected to act as an alternative reset.

(iv)Explain how the diode D in **Fig. 1** provides protection from the inductive load caused by the relay. [2 marks]

Blank Page

(Questions continue overleaf)

(b) Fig. 2 shows an LED arrangement and a motor. These two output devices are to be connected to a separate power supply of 12V and operated by a relay as directed in the circuit shown in **Fig. 1**.

Fig. 2

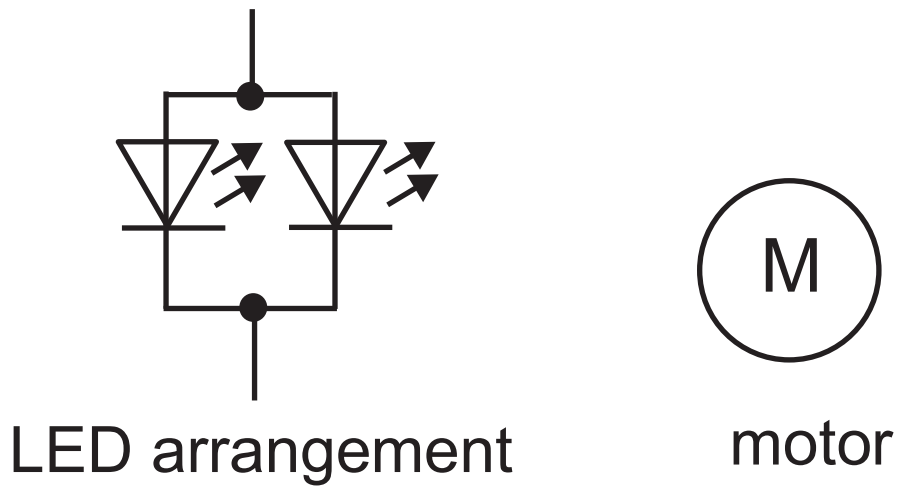

- (i) Calculate the power dissipated, in watts, by the motor shown in **Fig. 2** if it has an operational current of 350 mA. [2 marks]

Candidates need to show their working out in the space below.

Answer _____ W

- (ii) Calculate the required value of a protective resistor in ohms for the LED arrangement shown in **Fig. 2** if each LED operates at a forward voltage of 2.5 V and a current of 22 mA. [3 marks]

Candidates need to show their working out in the space below.

Answer _____ Ω

Blank Page

(Questions continue overleaf)

(ii) Following production of the circuit shown in **Fig. 3**, testing is to be carried out to check for faults. Explain **one** safety procedure that should be implemented when testing electronic systems. [2 marks]

2 (a) The voltage divider circuit shown in **Fig. 4** opposite is to be used to sense the temperature in a greenhouse. The resistance/temperature characteristic for the thermistor R_{th} is also shown.

(i) Explain **one** reason for using a variable resistor rather than a fixed resistor in the voltage divider circuit shown in **Fig. 4**. [2 marks]

Fig. 4

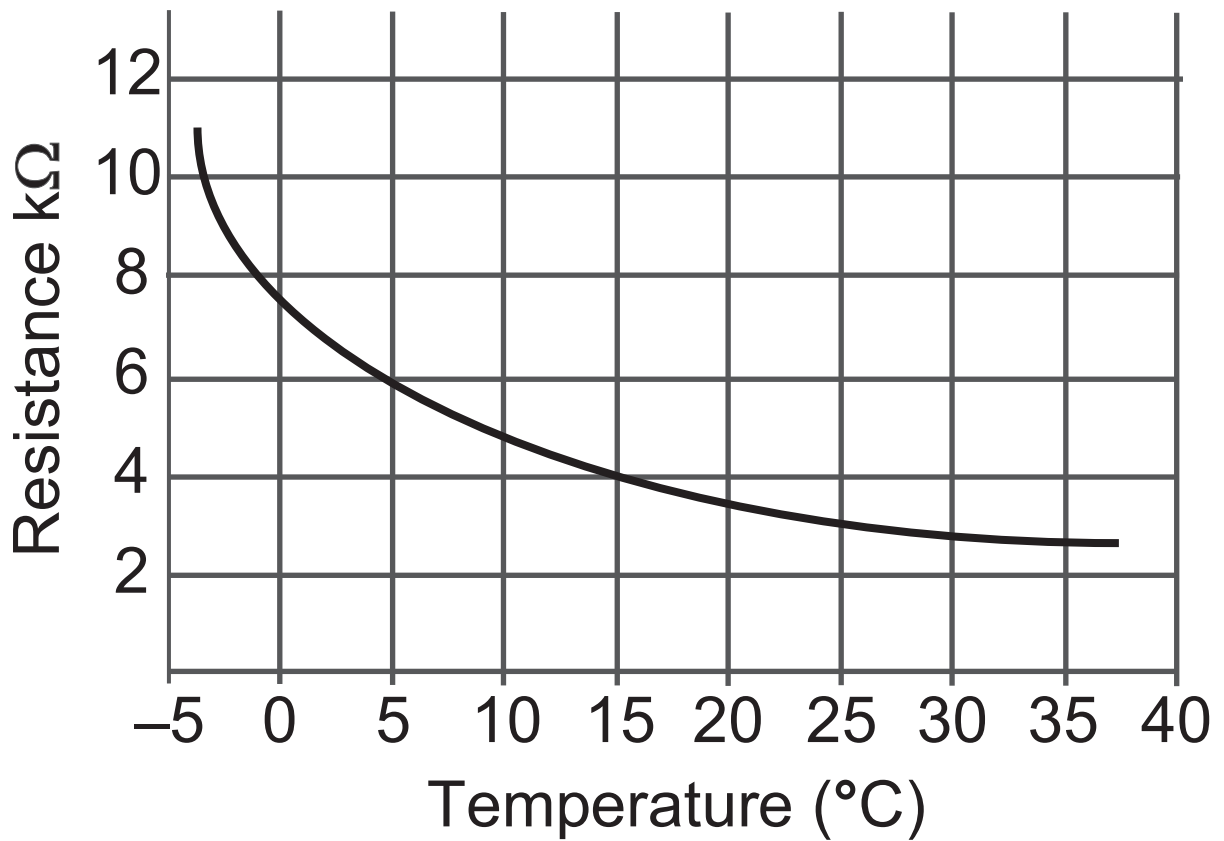
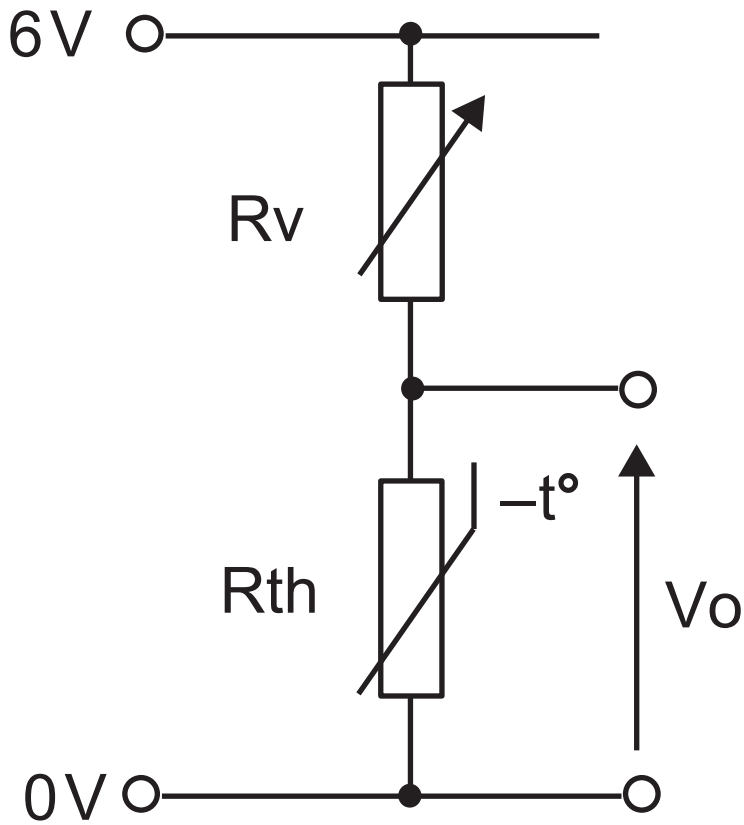

(ii) Calculate the resistance of R_v , in $k\Omega$, required to obtain a V_o of 2.5 V in **Fig. 4** when the air temperature is 15°C . [3 marks]

Candidates need to show their working out in the space below.

Answer _____ $k\Omega$

(iii) With reference to the relationship between temperature and the output voltage V_o , explain the effect of swapping the positions of R_{th} and R_v in **Fig. 4**. [2 marks]

(b) The symbol for a comparator, which is to be used as part of a system to detect temperature changes in a greenhouse, is shown in **Fig. 5**. The output voltage V_o from the voltage divider in **Fig. 4** is to be used as one of the inputs to the comparator.

Fig. 5

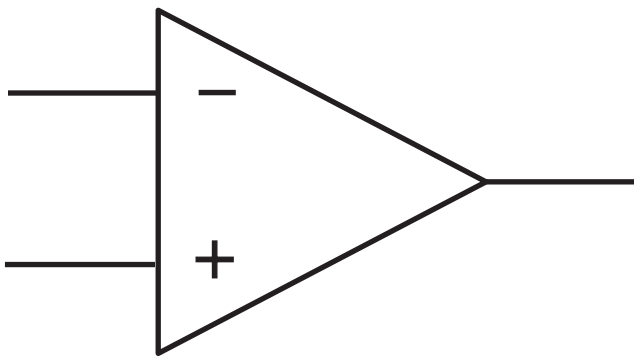

(i) Describe **one** feature of a comparator that makes it suitable for use as part of a system to detect small changes in temperature. [2 marks]

(ii) The greenhouse temperature detector based on a comparator is required to produce a positive output voltage to activate an alarm when the temperature drops below a preset level.

Draw the complete circuit design for the greenhouse detector system on **Fig. 6** opposite by adding the following: [5 marks]

- a $\pm 6\text{ V}$ dual power supply
- both inputs as required for the comparator to operate
- a buzzer driven by a transistor connected to the output of the comparator.

Fig. 6

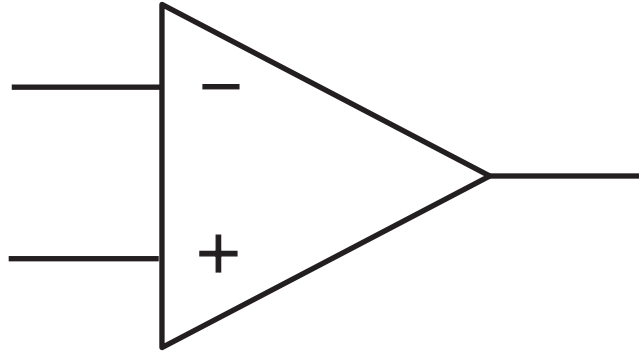

(c) As a further development, the buzzer on the greenhouse temperature detector will repeatedly sound on and off when the comparator detects a low temperature. This will be achieved by inserting a 555 timer between the comparator and the buzzer driver as shown in **Fig. 7** opposite.

(i) State if the system shown in **Fig. 7** can be considered as on/off or continuous and justify your answer. [1 mark for answer, 2 marks for justification]

Answer _____

Justification _____

Fig. 7

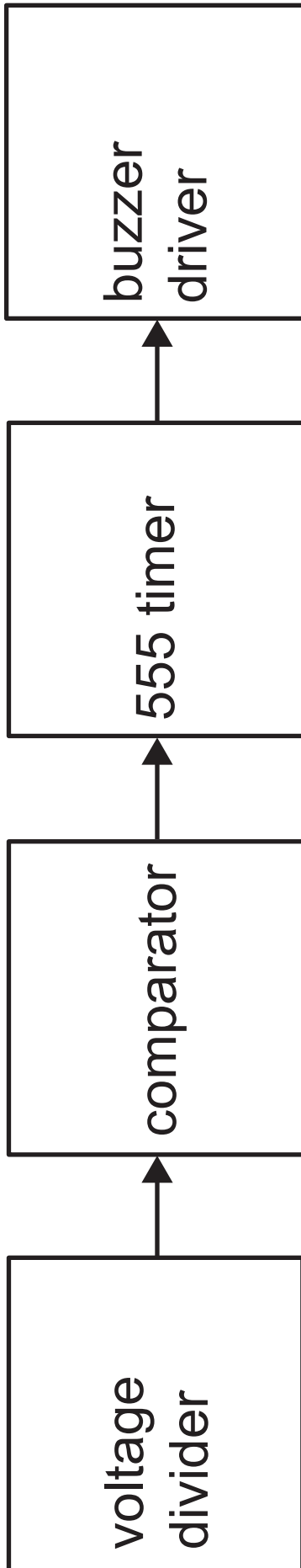

- (ii) The 555 circuit to be used is shown in Fig. 8. Calculate the required value of the capacitor C , in microfarads (μF), to achieve an output frequency of 2 hertz if $R_1 = 18\text{ k}\Omega$ and $R_2 = 27\text{ k}\Omega$. [3 marks]

Fig. 8

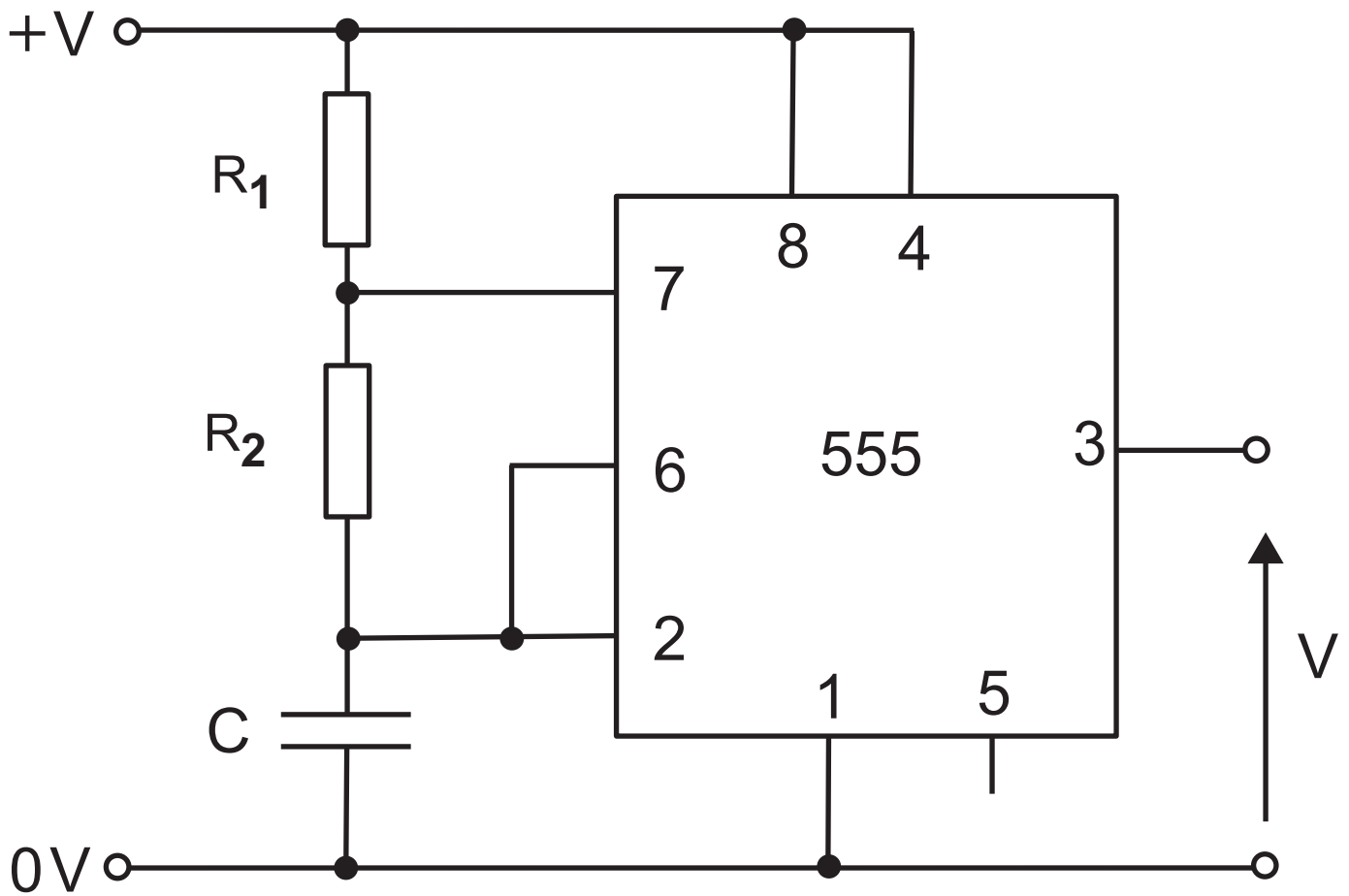

**Candidates need to show their
working out in the space below.**

Answer _____ μF

Section B

Mechanical and Pneumatic Control Systems

Answer **both** questions in this section.

- 3 Fig. 9** opposite shows a prototype control system for an exhibit in a museum display. The exhibit rotates on a large turntable with a pneumatic system that causes the animatronic dinosaur to lunge forward and open its jaws when it is facing the viewing area.

Fig. 9

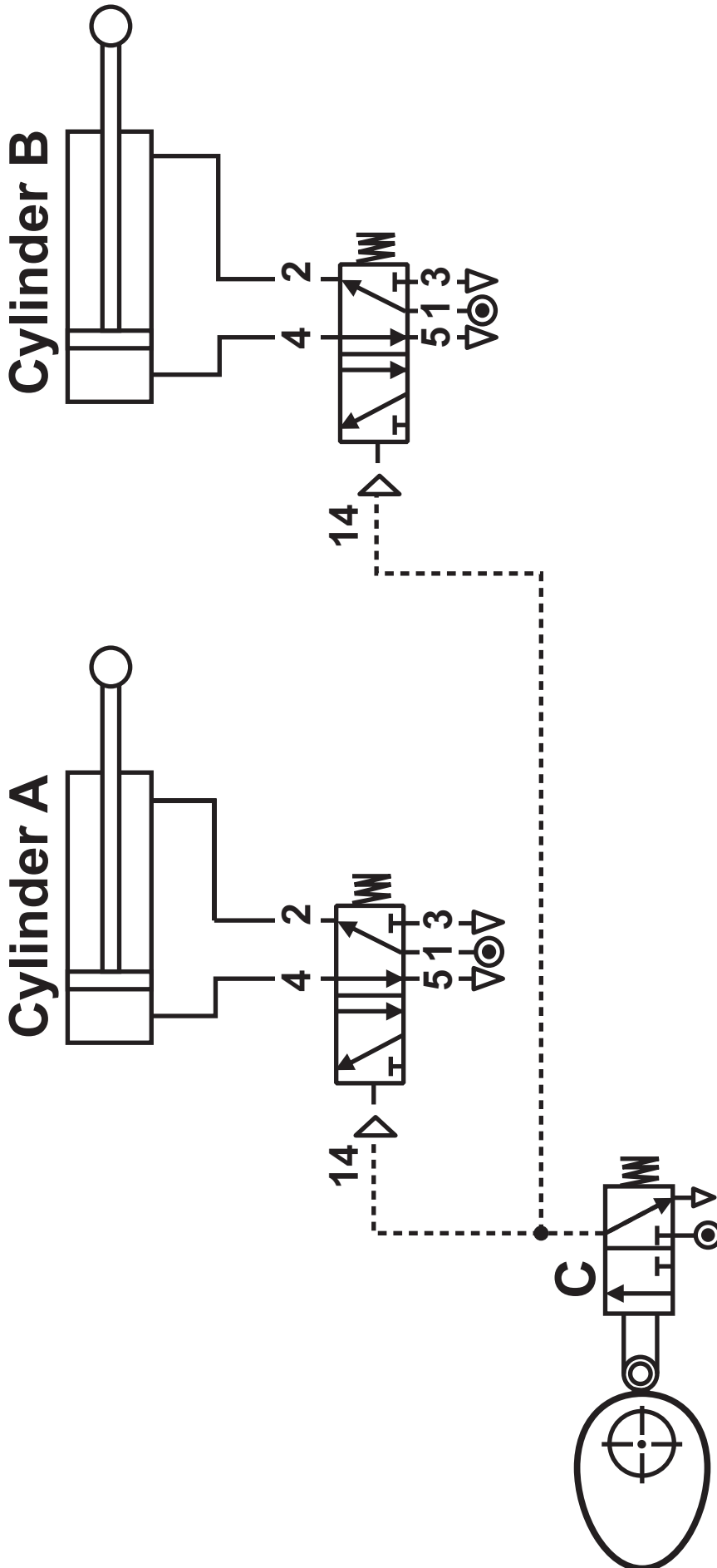
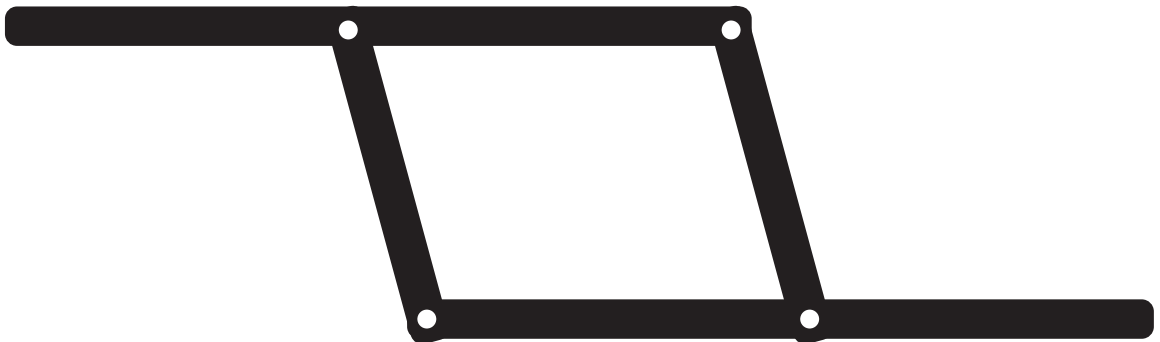

Fig. 10 opposite shows the skeleton of the exhibit before and after the pneumatic circuit is activated.

(a) Name the mechanism which activates the roller on three port valve **C** shown in **Fig. 9**. [1 mark]

Fig. 11



(b) The linkage system shown in **Fig. 11** is used to control the motion of the dinosaur exhibit.

State the name of this linkage.
[1 mark]

Fig. 10

Before activation

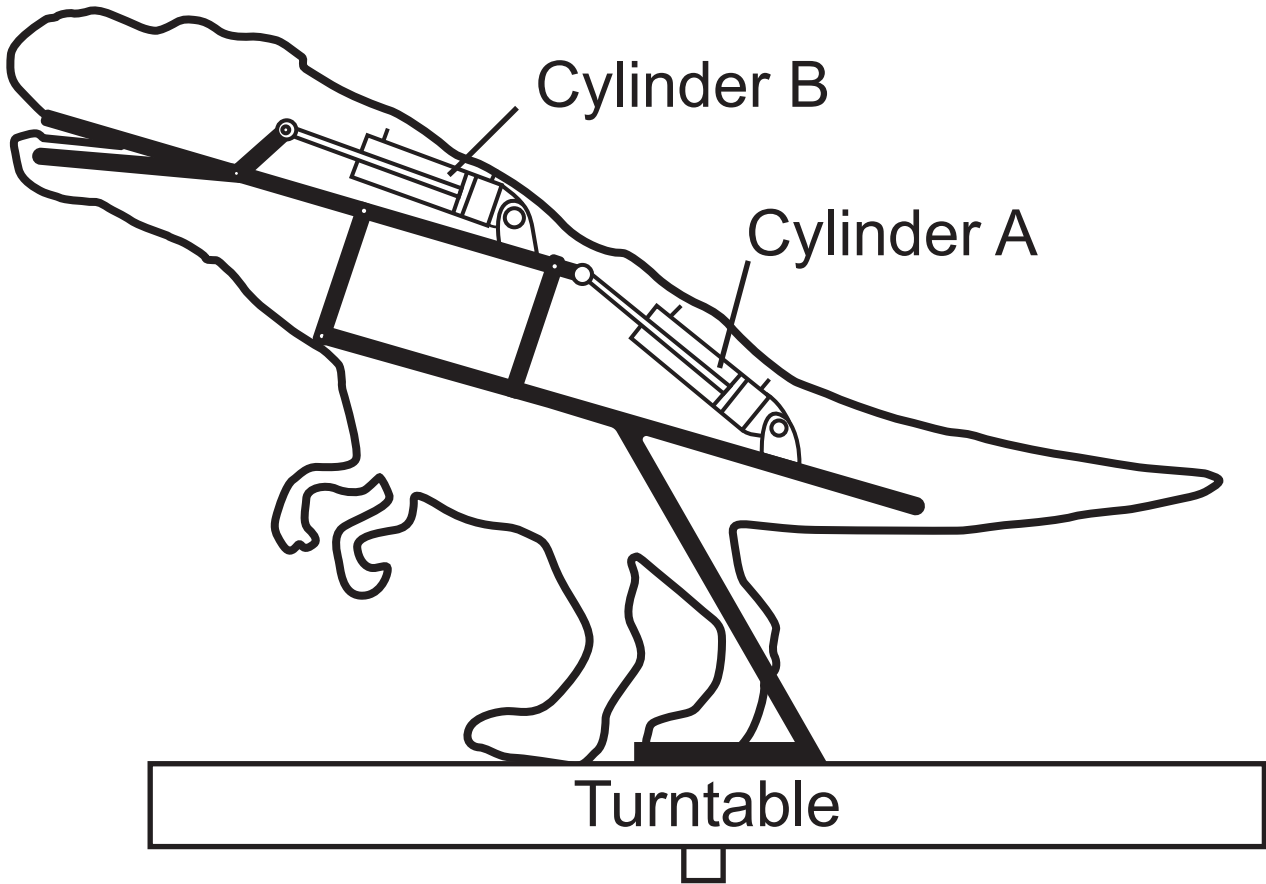

When pneumatics are activated

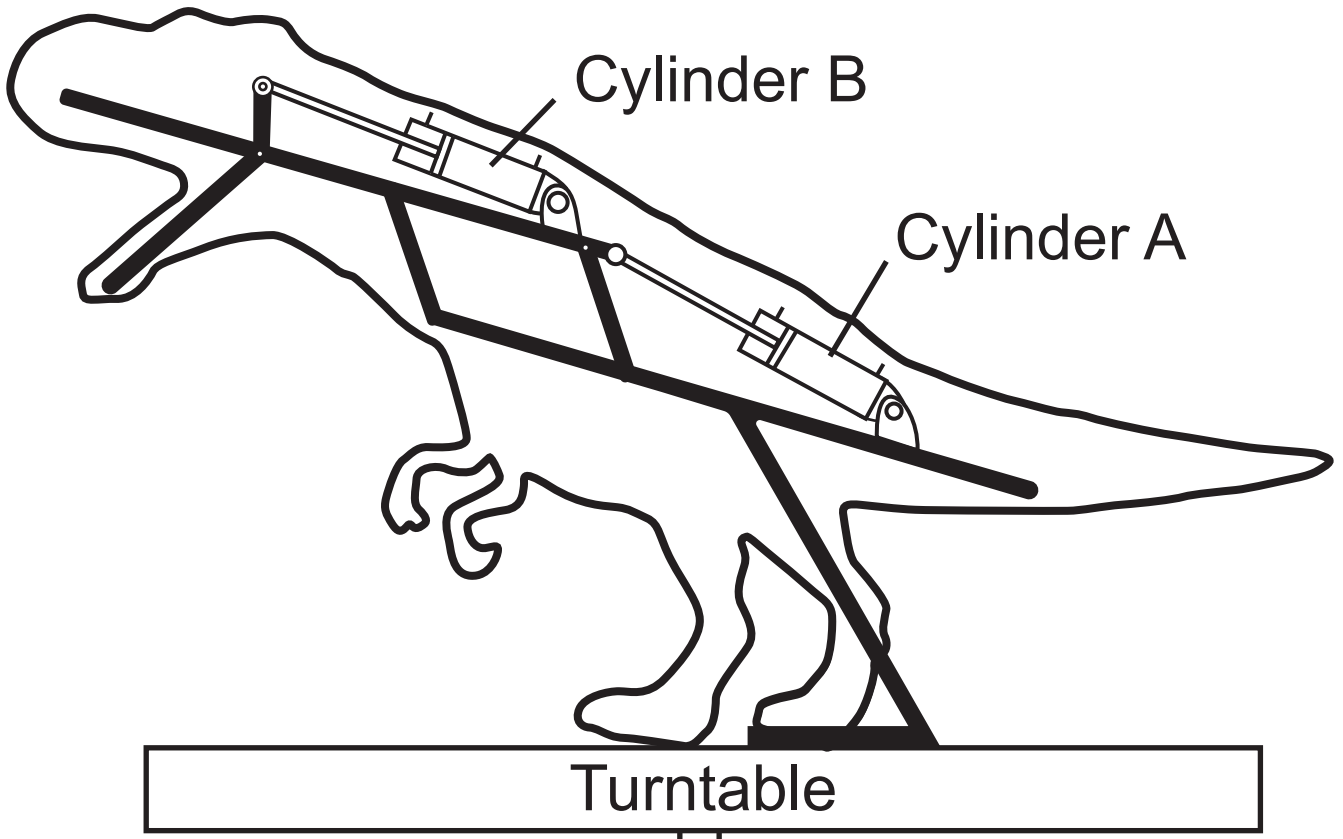

(c) Explain the three main stages in conditioning compressed air before it can be used in a pneumatic system.
[2 marks for each]

1. Filtration

2. Pressure regulation

3. Lubrication

Blank Page

(Questions continue overleaf)

(d) During testing it was found that the operation of the pneumatic circuit in **Fig. 9** should be changed to improve the realism of the motion of the exhibit.

Complete the circuit in **Fig. 12** opposite so that upon activation of the roller trip at the 5 port valve **D** the circuit will operate in the sequence **A+**, **B+** and upon release of the roller trip 5 port valve **D** the circuit will operate in the sequence **B-**, **A-**. [6 marks]

(e) The museum exhibit is mounted on a large revolving turntable which is driven by an electric motor coupled to a drive train shown opposite in **Fig. 13**.

Calculate the velocity ratio between gear A and pulley wheel G. [5 marks]

Candidates need to show their working out in the space below.

Answer _____

Fig. 13

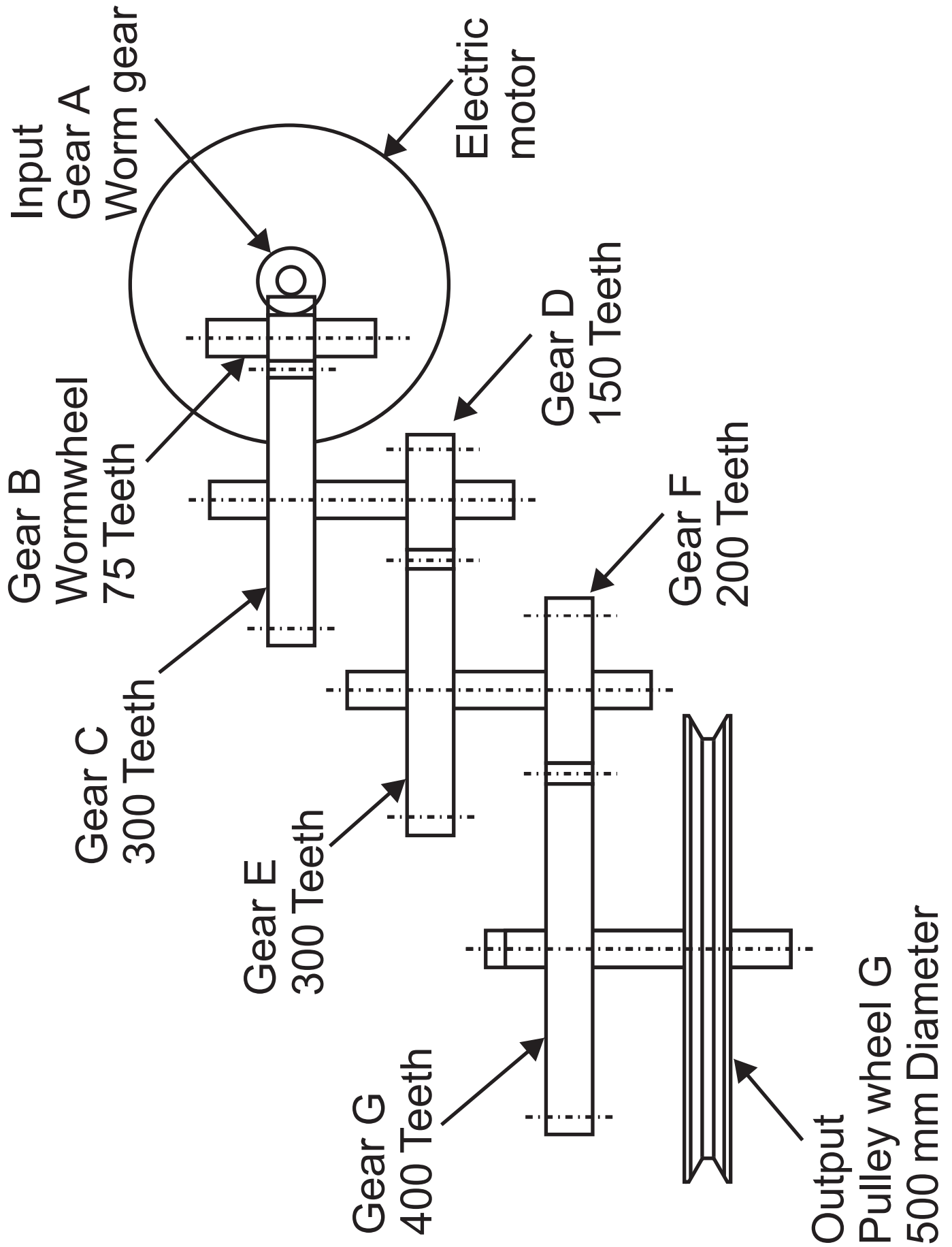

- (f) Calculate the output speed of the drive train if the input speed of the worm gear is 3000 RPM. [1 mark]

Candidates need to show their working out in the space below.

Answer _____ RPM

Blank Page

(Questions continue overleaf)

4 Fig. 14 opposite shows a clamping device operated by a pneumatic cylinder. The cylinder is supplied with an air pressure of 0.2 N/mm^2 , has a piston diameter of 40 mm and a piston rod diameter of 15 mm .

(a) (i) Calculate the force provided by the cylinder during the outstroke.
[4 marks]

Assume $\pi = 3.14$.

Candidates need to show their working out in the space below.

Answer _____ N

Fig. 14

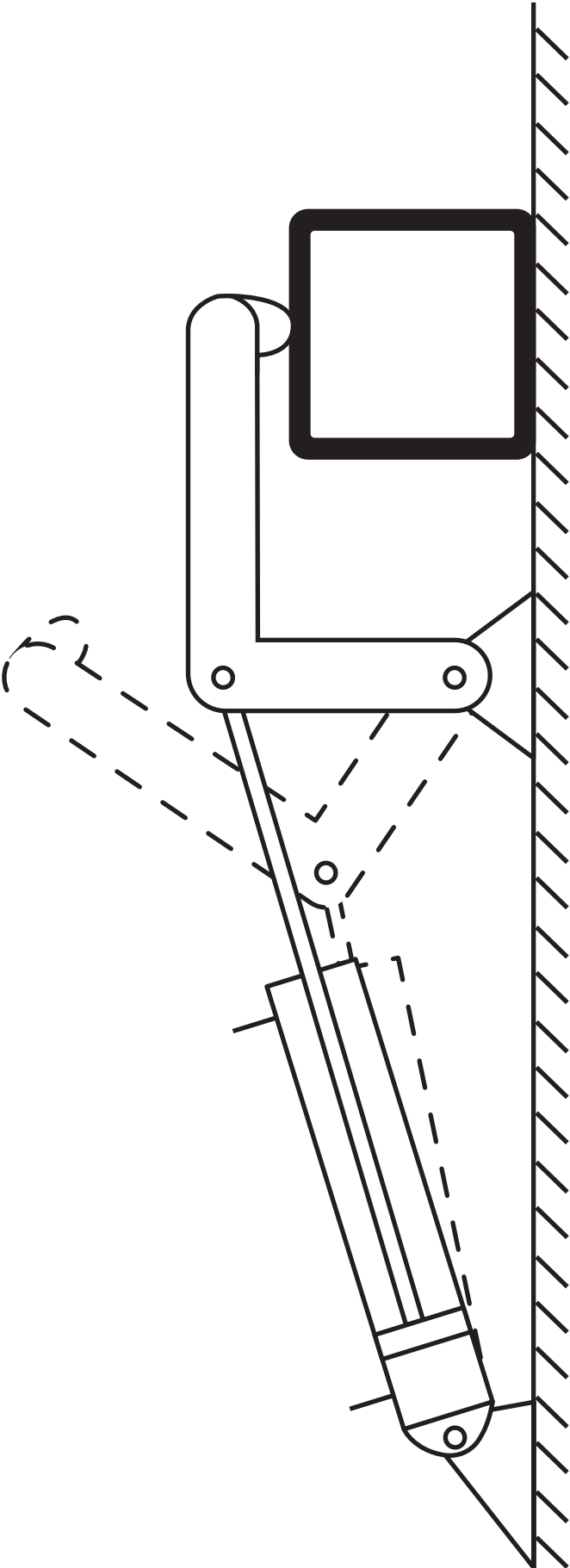

A cylinder is arranged in a different configuration to clamp a workpiece as shown in **Fig. 15**.

Fig. 15

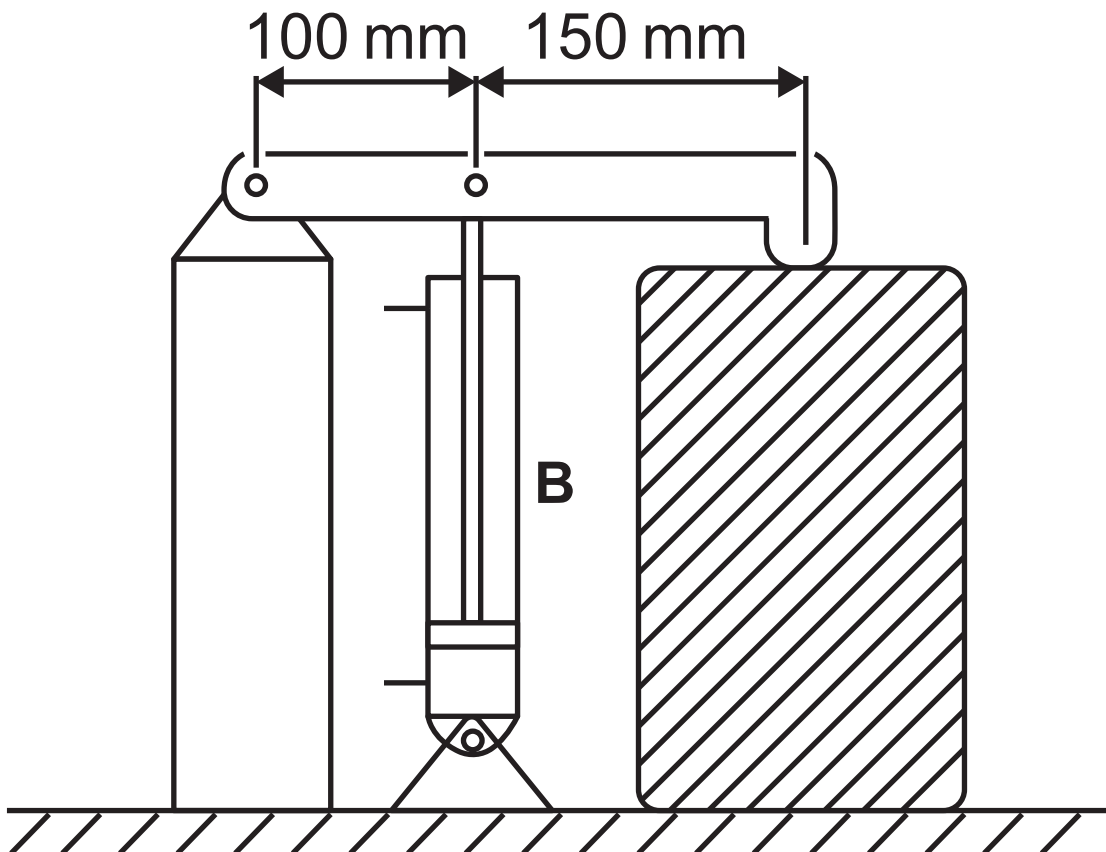

Data for cylinder B	
Diameter of piston D	38 mm
Diameter of piston rod d	10 mm
Air pressure	0.2 N/mm^2
π	3.14

(ii) State the class of lever shown in **Fig. 15.** [1 mark]

Answer _____

(iii) Calculate the force produced by cylinder **B** in **Fig. 15** when it is activated to **instroke** with an air pressure of 0.2 N/mm^2 . [4 marks]

Assume $\pi = 3.14$.

Candidates need to show their working out in the space below.

Answer _____

(iv) A lever used in a clamping mechanism is shown in **Fig. 16**.

Fig. 16

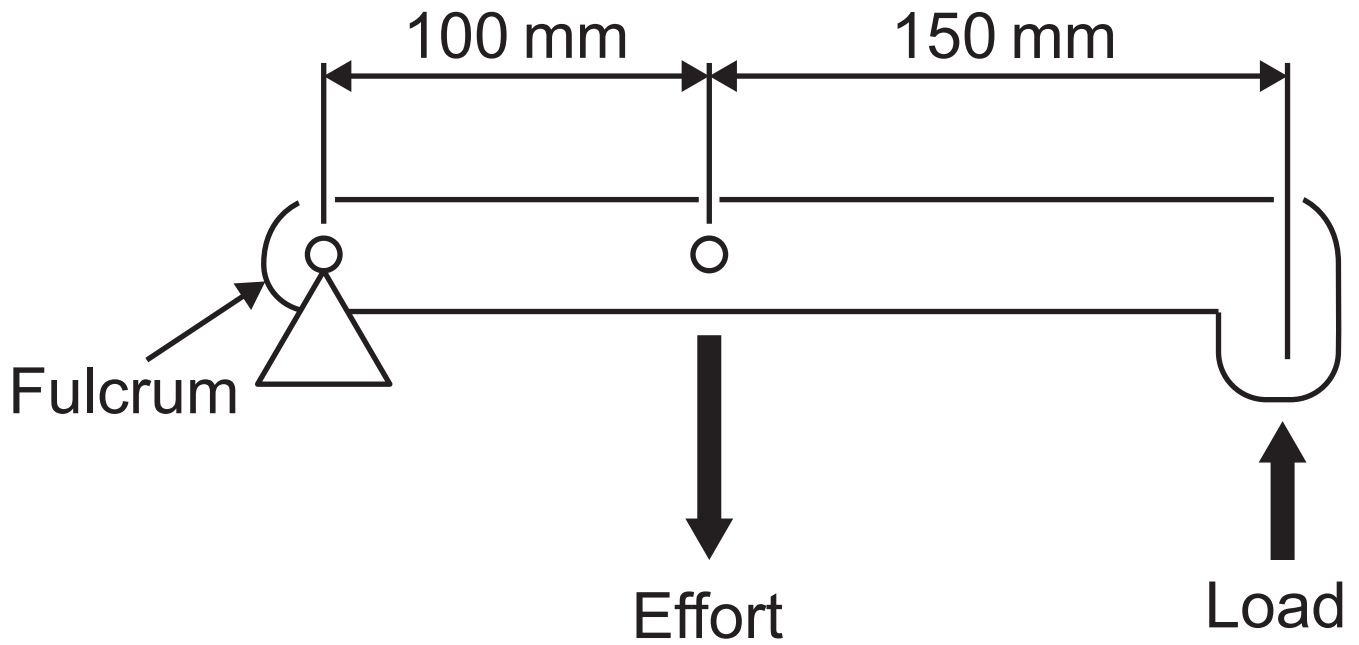

Calculate the mechanical advantage produced by the lever shown in **Fig. 16**. [1 mark]

Candidates need to show their working out in the space below.

Answer _____

(b) Complete **Fig. 17** with an annotated sketch of a suitable mechanism which could connect the motor shaft **A** to output shaft **B** with a velocity ratio of 2.0.
[3 marks]

Fig. 17

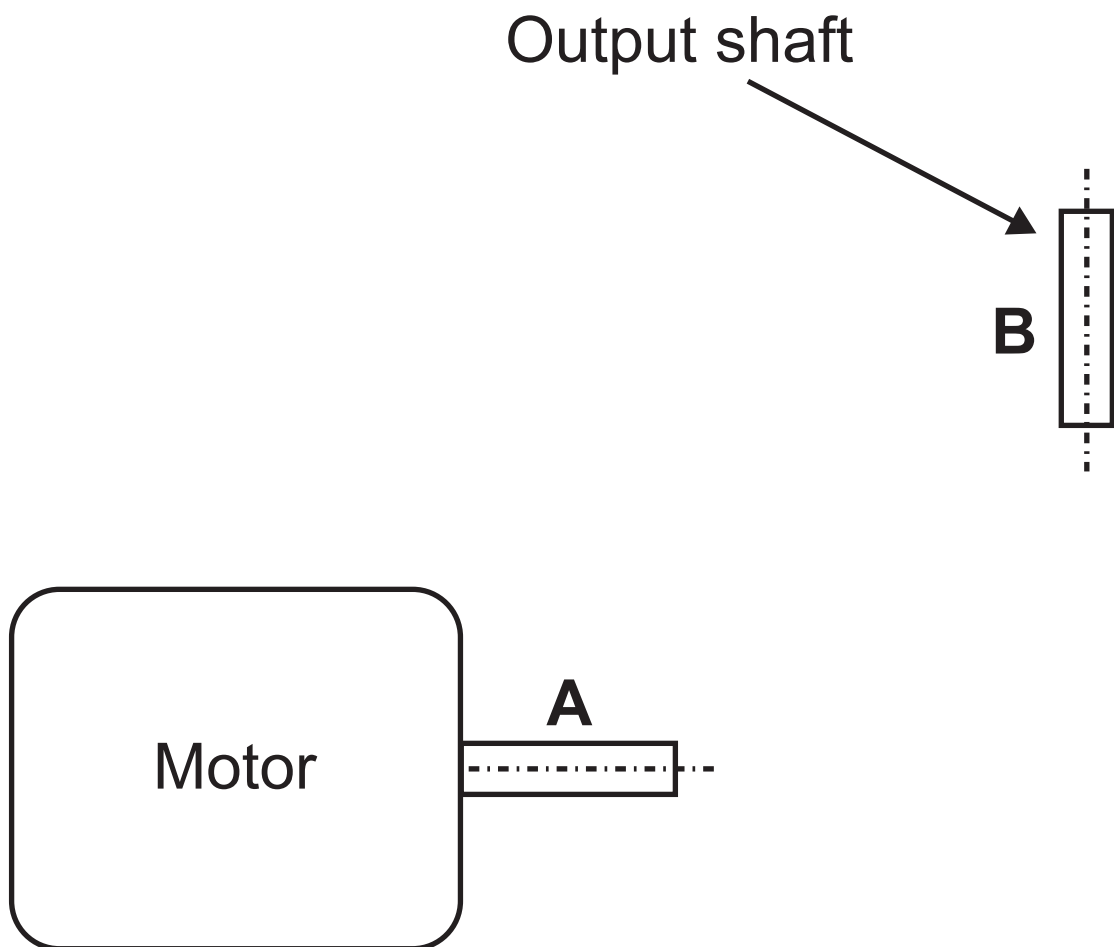

(c) Complete the circuit shown in **Fig. 18** opposite so that activation of the 3/2 valve **A** causes the single acting cylinder **B** to operate with a time delay on the outstroke. [3 marks]

(d) Explain **one** safety consideration when working with pneumatic systems and explain **one** safety consideration when working with mechanical systems. [2 marks for each]

Pneumatics

Mechanical

Fig. 18

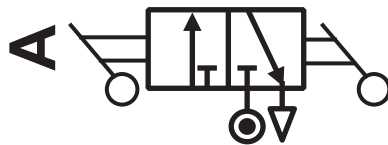
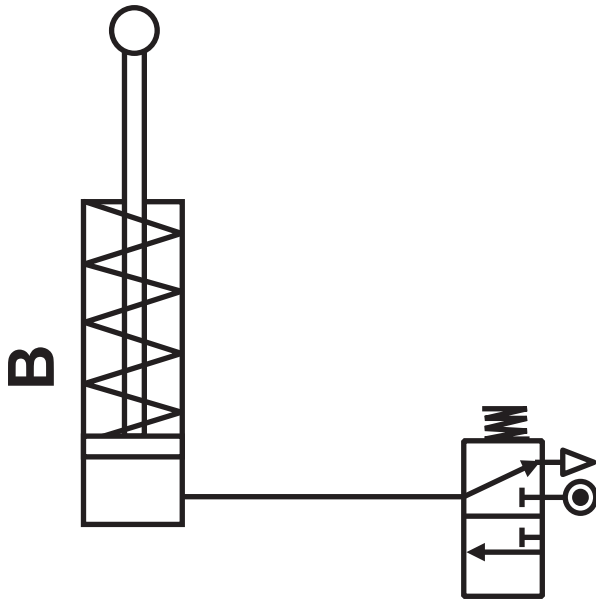

Section C

Product Design

Answer **both** questions in this section.

- 5 A local company that designs and manufactures guitars provides a range of models to suit the customer's skill level and preferences. **Fig. 19** shows one of the models, a classic junior guitar aimed at the young beginner.

Fig. 19

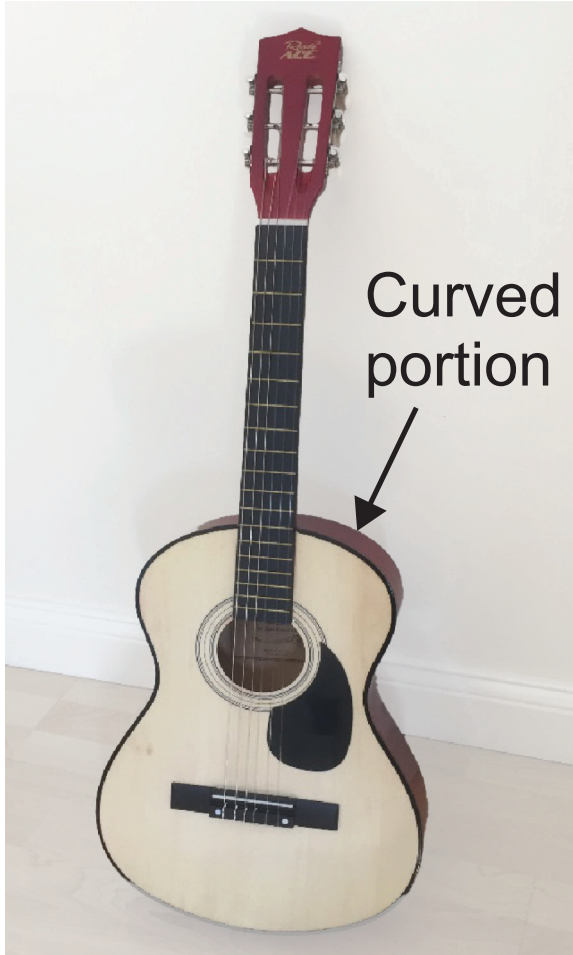

(a) When conducting research for the guitars a survey was used by the company.

Explain what is meant by a survey.

[2 marks]

(b) Before commencing production of the guitars the product must comply with British Standards and employee and consumer safety.

(i) State **two** characteristics associated with British Standards.

[1 mark for each]

1. _____

2. _____

(ii) Distinguish between employee and consumer safety. [2 marks]

(c) To assist in the planning for manufacture of the guitars a flow process chart is to be used.

Briefly outline **two** characteristics associated with a flow process chart.

[1 mark for each]

1. _____

2. _____

(d) The company uses quick response manufacture (QRM) as the preferred method to organise the design and production for all the guitar products it produces.

Briefly outline **two** characteristics associated with QRM.

[1 mark for each]

1. _____

2. _____

(e) A prototype model of the guitar is to be manufactured by laminating the wood.

Explain how the curved portion of the guitar shown in **Fig. 19** could be manufactured using the laminating process. [2 marks]

- (f) Throughout the design process, designers from the company engaged with the client by using formative and summative evaluation techniques.

Distinguish between formative and summative evaluation techniques.

[2 marks]

- (g) With reference to **Fig. 20** opposite and using the blank A4 pro forma (answer number **5(g)**) complete the following using detailed annotated sketches:

An appropriate compact design for a stand which will hold the guitar at approximately 80 mm off the floor and at an angle of approximately 60° to the floor. Your design must be able to be quickly and easily folded and unfolded for use and should minimise the use of materials and storage space. [6 marks]

Fig. 20



Pro forma answer page (answer no. **5 (g)**)

6 Fig. 21 shows a photograph of a garden vacuum.



A company that designs and manufactures a wide range of garden products such as the garden vacuum shown in **Fig. 21** is keen to adopt a continuous improvement approach.

- (a)** Explain what is meant by the term continuous improvement and give **one** reason why the company would want to adopt this approach.
[2 marks for explanation,
1 mark for reason]

Reason

(b) To help generate ideas for the garden vacuum the company uses the technique of attribute analysis.

With reference to **Fig. 21** explain how attribute analysis could be used to help generate ideas for the garden vacuum.
[2 marks]

(c) Prior to production of the garden vacuum a work order was created.

Explain what is meant by a work order.
[2 marks]

(d) An idea that emerged during the development of the product was to manufacture the vacuum tube shown in **Fig. 21** from carbon fibre reinforced plastic (CFRP).

(i) State **two** properties associated with CFRP which would make it suitable for the vacuum tube. [2 marks]

1. _____

2. _____

(ii) State **one** reason why CFRP may be considered as an unsuitable material for the vacuum tube. [1 mark]

(e) The company has developed a new logo and plans to manufacture a new metal sign for the front of its business premises. This metal sign is to be manufactured by using a water jet cutting process.

With the use of an annotated sketch explain the water jet cutting process.
[4 marks]

(f) After discussing the intellectual property rights for the garden vacuum the design team decided to apply for a registered design.

Briefly outline **two** specific characteristics associated with a registered design.

[2 marks]

1. _____

2. _____

(g) The company plans to develop the vacuum tube to make the product easier for the user to operate.

Fig. 22 on page 58 shows a photograph of the garden vacuum and a cross sectional view on X–X of the vacuum tube.

Using the blank A4 pro forma (answer number **6(g)** page 59) use detailed annotated sketches to produce **one** possible solution for the following:

A suitable design that can be securely attached to the bottom of the vacuum tube to ensure that the tube will remain at least 50 mm off the ground during use, whilst maintaining the manoeuvrability of the product. [4 marks]

Fig. 22



**Cross sectional view on X–X
of the vacuum tube**

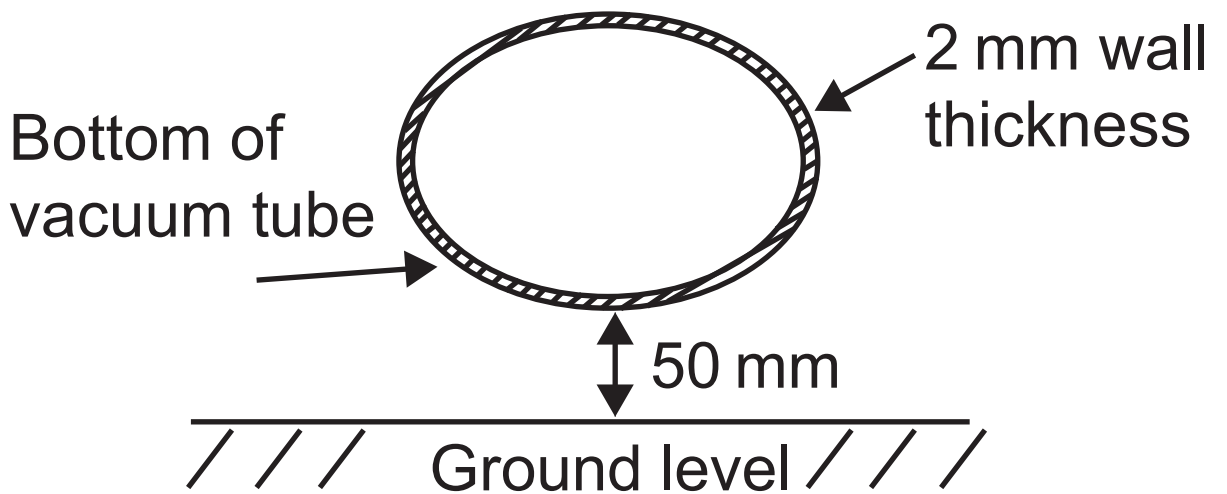

Pro forma answer page (answer no. **6 (g)**)

SOURCES

All sources © CCEA unless stated otherwise

**This is the end of the
question paper**

For Examiner's use only	
Question Number	Marks
1	
2	
3	
4	
5	
6	

Total Marks	
--------------------	--

Examiner Number

Permission to reproduce all copyright material has been applied for.
In some cases, efforts to contact copyright holders may have been unsuccessful and CCEA will be happy to rectify any omissions of acknowledgement in future if notified.